

INTERNATIONAL STANDARD

ISO
6336-6

First edition
2006-08-15

Calculation of load capacity of spur and helical gears —

Part 6:

Calculation of service life under variable load

*Calcul de la capacité de charge des engrenages cylindriques
à dentures droite et hélicoïdale —*

Partie 6: Calcul de la durée de vie en service sous charge variable



Reference number
ISO 6336-6:2006(E)

PDF disclaimer

This PDF file may contain embedded typefaces. In accordance with Adobe's licensing policy, this file may be printed or viewed but shall not be edited unless the typefaces which are embedded are licensed to and installed on the computer performing the editing. In downloading this file, parties accept therein the responsibility of not infringing Adobe's licensing policy. The ISO Central Secretariat accepts no liability in this area.

Adobe is a trademark of Adobe Systems Incorporated.

Details of the software products used to create this PDF file can be found in the General Info relative to the file; the PDF-creation parameters were optimized for printing. Every care has been taken to ensure that the file is suitable for use by ISO member bodies. In the unlikely event that a problem relating to it is found, please inform the Central Secretariat at the address given below.

© ISO 2006

All rights reserved. Unless otherwise specified, no part of this publication may be reproduced or utilized in any form or by any means, electronic or mechanical, including photocopying and microfilm, without permission in writing from either ISO at the address below or ISO's member body in the country of the requester.

ISO copyright office
Case postale 56 • CH-1211 Geneva 20
Tel. + 41 22 749 01 11
Fax + 41 22 749 09 47
E-mail copyright@iso.org
Web www.iso.org

Published in Switzerland

Contents

	Page
Foreword.....	iv
1 Scope	1
2 Normative references	1
3 Terms, definitions, symbols and abbreviated terms.....	1
4 General.....	1
4.1 Application factors	1
4.2 Determination of load and stress spectra	1
4.3 General calculation of service life.....	4
4.4 Palmgren-Miner rule	5
5 Calculation according to ISO 6336 of service strength on basis of single-stage strength	5
5.1 Basic principles	5
5.2 Calculation of stress spectra.....	7
5.3 Determination of pitting and bending strength values	8
5.4 Determination of safety factors	8
Annex A (normative) Determination of application factor, K_A, from given load spectrum using equivalent torque, T_{eq}.....	10
Annex B (informative) Guide values for application factor, K_A	15
Annex C (informative) Example calculation of safety factor from given load spectrum	18
Bibliography	24

Foreword

ISO (the International Organization for Standardization) is a worldwide federation of national standards bodies (ISO member bodies). The work of preparing International Standards is normally carried out through ISO technical committees. Each member body interested in a subject for which a technical committee has been established has the right to be represented on that committee. International organizations, governmental and non-governmental, in liaison with ISO, also take part in the work. ISO collaborates closely with the International Electrotechnical Commission (IEC) on all matters of electrotechnical standardization.

International Standards are drafted in accordance with the rules given in the ISO/IEC Directives, Part 2.

The main task of technical committees is to prepare International Standards. Draft International Standards adopted by the technical committees are circulated to the member bodies for voting. Publication as an International Standard requires approval by at least 75 % of the member bodies casting a vote.

Attention is drawn to the possibility that some of the elements of this document may be the subject of patent rights. ISO shall not be held responsible for identifying any or all such patent rights.

ISO 6336-6 was prepared by Technical Committee ISO/TC 60, *Gears*, Subcommittee SC 2, *Gear capacity calculation*.

ISO 6336 consists of the following parts, under the general title *Calculation of load capacity of spur and helical gears*:

- *Part 1: Basic principles, introduction and general influence factors*
- *Part 2: Calculation of surface durability (pitting)*
- *Part 3: Calculation of tooth bending strength*
- *Part 5: Strength and quality of materials*
- *Part 6: Calculation of service life under variable load*

Calculation of load capacity of spur and helical gears —

Part 6:

Calculation of service life under variable load

1 Scope

This part of ISO 6336 specifies the information and standardized conditions necessary for the calculation of the service life (or safety factors for a required life) of gears subject to variable loading. While the method is presented in the context of ISO 6336 and calculation of the load capacity of spur and helical gears, it is equally applicable to other types of gear stress.

2 Normative references

The following referenced documents are indispensable for the application of this document. For dated references, only the edition cited applies. For undated references, the latest edition of the referenced document (including any amendments) applies.

ISO 1122-1:1998, *Glossary of gear terms — Part 1: Geometrical definitions*

ISO 6336-1:2006, *Calculation of load capacity of spur and helical gears — Part 1: Basic principles, introduction and general influence factors*

ISO 6336-2:2006, *Calculation of load capacity of spur and helical gears — Part 2: Calculation of surface durability (pitting)*

ISO 6336-3:2006, *Calculation of load capacity of spur and helical gears — Part 3: Calculation of tooth bending strength*

3 Terms, definitions, symbols and abbreviated terms

For the purposes of this part of ISO 6336, the terms, definitions, symbols and abbreviated terms given in ISO 6336-1 and ISO 1122-1 apply.

4 General

4.1 Application factors

If no load spectra are available, application factors from experience with similar machines may be used, depending on the operating mode of the driving and driven machine instead of calculation of the service strength.

See Annex B for tables for K_A .

4.2 Determination of load and stress spectra

Variable loads resulting from a working process, starting process or from operation at or near a critical speed will cause varying stresses at the gear teeth of a drive system. The magnitude and frequency of these loads depend upon the driven machine(s), the driver(s) or motor(s) and the mass elastic properties of the system.

These variable loads (stresses) may be determined by such procedures as

- experimental measurement of the operating loads at the machine in question,
- estimation of the spectrum, if this is known, for a similar machine with similar operating mode, and
- calculation, using known external excitation and a mass elastic simulation of the drive system, preferably followed by experimental testing to validate the calculation.

To obtain the load spectra for fatigue damage calculation, the range of the measured (or calculated) loads is divided into bins or classes. Each bin contains the number of load occurrences recorded in its load range. A widely used number of bins is 64. These bins can be of equal size, but it is usually better to use larger bin sizes at the lower loads and smaller bin sizes at the upper loads in the range. In this way, the most damaging loads are limited to fewer calculated stress cycles and the resulting gears can be smaller. It is recommended that a zero load bin be included so that the total time used to rate the gears matches the design operating life. For consistency, the usual presentation method is to have the highest torque associated with the lowest numbered bins, such that the most damaging conditions appear towards the top of any table.

The cycle count for the load class corresponding to the load value for the highest loaded tooth is incremented at every load repetition. Table 1 shows as an example of how the torque classes defined in Table 2 can be applied to specific torque levels and correlated numbers of cycles.

Table 1 — Torque classes/numbers of cycles — Example: classes 38 and 39 (see Table 2)

Torque class, T_i N·m	Number of cycles, n_i
$11\ 620 \leq T_{38} \leq 12\ 619$	$n_{38} = 237$
$10\ 565 \leq T_{39} \leq 11\ 619$	$n_{39} = 252$

The torques used to evaluate tooth loading should include the dynamic effects at different rotational speeds.

This spectrum is only valid for the measured or evaluated time period. If the spectrum is extrapolated to represent the required lifetime, the possibility that there might be torque peaks not frequent enough to be evaluated in that measured spectrum must be considered. These transient peaks can have an effect on the gear life. Therefore, the evaluated time period could have to be extended to capture extreme load peaks.

Stress spectra concerning bending and pitting can be obtained from the load (torque).

Scuffing resistance must be calculated from the worst combination of speed and load.

Wear is a continuous deterioration of the tooth flank and must be considered separately.

Tooth root stress can also be measured by means of strain gauges in the fillet. In this case, the derating factors should be taken into account using the results of the measurements. The relevant contact stress can be calculated from the measurements.

Table 2 — Example of torque spectrum (with unequal bin size for reducing number of bins)
(see Annex C)

Data	Pinion		Load cycles ^a	%	Time ^a	
	Torque N·m				s	h
Bin no.	min.	max.				
1	25 502	25 578	0	0,00	0	0
2	25 424	25 501	0	0,00	0	0
3	25 347	25 423	14	0,37	24	0,006 7
4	25 269	25 346	8	0,21	14	0,003 9
5	25 192	25 268	5	0,13	9	0,002 5
6	25 114	25 191	8	0,21	14	0,003 9
7	25 029	25 113	16	0,42	28	0,007 8
8	24 936	25 028	8	0,21	14	0,003 9
9	24 835	24 935	5	0,13	9	0,002 5
10	24 727	24 834	11	0,29	19	0,005 3
11	24 610	24 726	16	0,42	28	0,007 8
12	24 479	24 609	19	0,50	33	0,009 2
13	24 331	24 478	14	0,37	24	0,006 7
14	24 168	24 330	14	0,37	24	0,006 7
15	23 990	24 168	11	0,29	19	0,005 3
16	23 796	23 989	15	0,39	26	0,007 2
17	23 579	23 796	31	0,81	52	0,014 4
18	23 339	23 579	28	0,73	47	0,013 1
19	23 076	23 338	36	0,94	62	0,017 2
20	22 789	23 075	52	1,36	88	0,024 4
21	22 479	22 788	39	1,02	66	0,018 3
22	22 138	22 478	96	2,51	163	0,045 3
23	21 766	22 137	106	2,77	180	0,050 0
24	21 363	21 765	49	1,28	83	0,023 1
25	20 929	21 362	117	3,05	200	0,055 6
26	20 463	20 928	124	3,24	212	0,058 9
27	19 960	20 463	61	1,59	104	0,028 9
28	19 417	19 959	140	3,65	238	0,066 1
29	18 836	19 416	148	3,86	253	0,070 3
30	18 216	18 835	117	3,05	200	0,055 6
31	17 557	18 215	121	3,16	206	0,057 2
32	16 851	17 556	174	4,46	297	0,082 5
33	16 100	16 851	185	4,83	316	0,087 8
34	15 301	16 099	196	5,11	334	0,092 8
35	14 456	15 301	207	5,40	352	0,097 8
36	13 565	14 456	161	4,20	274	0,076 1
37	12 620	13 564	168	4,38	286	0,079 4
38	11 620	12 619	237	6,18	404	0,112 2
39	10 565	11 619	252	6,58	429	0,119 2
40	9 457	10 565	263	6,86	449	0,124 7
41	8 294	9 456	275	7,18	468	0,130 0
42	7 070	8 294	178	4,65	303	0,084 2
43	5 783	7 069	103	2,69	176	0,048 9
44	4 434	5 782	7	0,18	12	0,003 3
45	3 024	4 434	0	0,00	0	0
46	1 551	3 023	0	0,00	0	0
47	1	1 550	0	0,00	0	0
48	0	0	0	0,00	6 041 469	1 678,2
		Total ≥	3 832	100,0	6 048 000	1 680

^a -10 raises and lowers; pinion at 35,2 r/min assumes 1 raise and lower per week.

4.3 General calculation of service life

The calculated service life is based on the theory that every load cycle (every revolution) is damaging to the gear. The amount of damage depends on the stress level and can be considered as zero for lower stress levels.

The calculated bending or pitting fatigue life of a gear is a measure of its ability to accumulate discrete damage until failure occurs.

The fatigue life calculation requires

- a) the stress spectrum,
- b) material fatigue properties, and
- c) a damage accumulation method.

The stress spectrum is discussed in 5.1.

Strength values based on material fatigue properties are chosen from applicable S-N curves. Many specimens must be tested by stressing them repeatedly at one stress level until failure occurs. This gives, after a statistical interpretation for a specific probability, a failure cycle number characteristic of this stress level. Repeating the procedure at different stress levels leads to an S-N curve.

An example of a cumulative stress spectrum is given in Figure 1. Figure 2 shows a cumulative contact stress spectrum with an S-N curve for specific material fatigue properties.

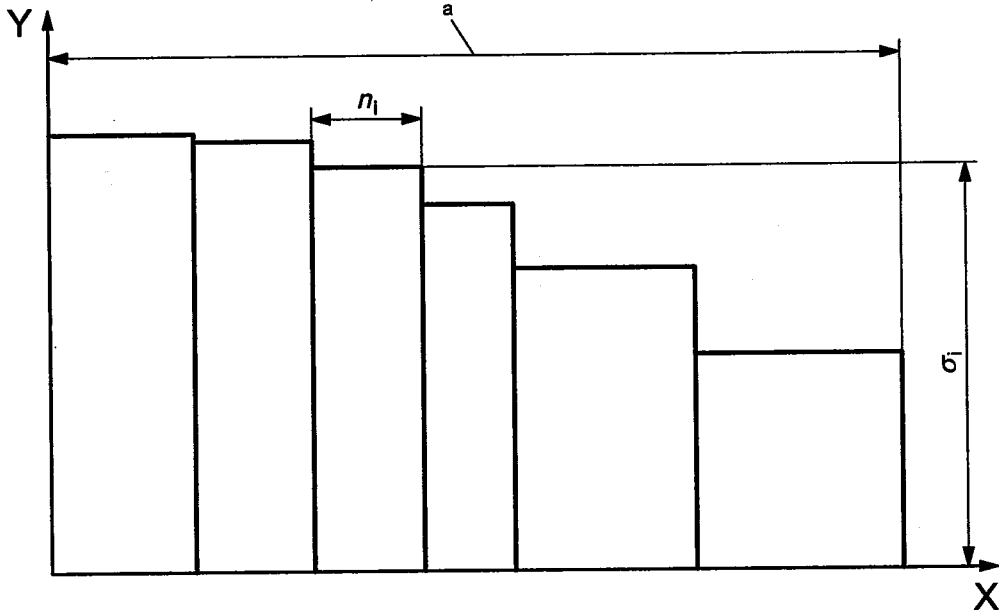

- Key**
- X cumulative number of applied cycles
 - Y stress
 - a Load spectrum, $\sum n_i$, total cycles.

Figure 1 — Example for a cumulative stress spectrum

Linear, non-linear and relative methods are used.

Further information can be found in the literature.

4.4 Palmgren-Miner rule

The Palmgren-Miner rule — in addition to other rules or modifications — is a widely used linear damage accumulation method. It is assumed that the damaging effect of each stress repetition at a given stress level is equal, which means the first stress cycle at a given stress level is as damaging as the last.

The Palmgren-Miner rule operates on the hypothesis that the portion of useful fatigue life used by a number of repeated stress cycles at a particular stress is equal to the ratio of the total number of cycles during the fatigue life at a particular stress level according to the S-N curve established for the material. For example, if a part is stressed for 3 000 cycles at a stress level which would cause failure in 100 000 cycles, 3 % of the fatigue life would be expended. Repeated stress at another stress level would consume another similarly calculated portion of the total fatigue life.

The used material fatigue characteristics and endurance data should be related to a specific and required failure probability, e.g. 1 %, 5 % or 10 %.

When 100 % of the fatigue life is expended in this manner, the part could be expected to fail. The order in which each of these individual stress cycles is applied is not considered significant in Palmgren-Miner analysis.

Failure could be expected when

$$\sum_i \frac{n_i}{N_i} = 1,0 \quad (1)$$

where

n_i is the number of load cycles for bin i ;

N_i is the number of load cycles to failure for bin i (taken from the appropriate S-N curve).

If there is an endurance limit (upper, horizontal line beyond the knee in Figure 2), the calculation is only done for stresses above this endurance limit.

If the appropriate S-N curve shows no endurance limit (lower line beyond the knee in Figure 2), the calculation must be done for all stress levels. For each stress level, i , the number of cycles to failure, N_i , have to be taken from the corresponding part of the S-N curve.

5 Calculation according to ISO 6336 of service strength on basis of single-stage strength

5.1 Basic principles

This method is only valid for recalculation. It describes the application of linear cumulative damage calculations according to the Palmgren-Miner rule (see 4.4) and has been chosen because it is widely known and easy to apply; the choice does not imply that the method is superior to others described in the literature.

From the individual torque classes, the torques at the upper limit of each torque class and the associated numbers of cycles shall be listed (see Table 3 for an example).

Table 3 — Torque classes/numbers of cycles — Example: classes 38 and 39

Upper limit of torque class ^a , T_i N·m	Number of cycles, n_i
$T_{38} < 12\,620$	$N_{38} = 237$
$T_{39} < 11\,620$	$N_{39} = 252$

^a For conservative calculation, sufficiently accurate for a high number of torque classes.

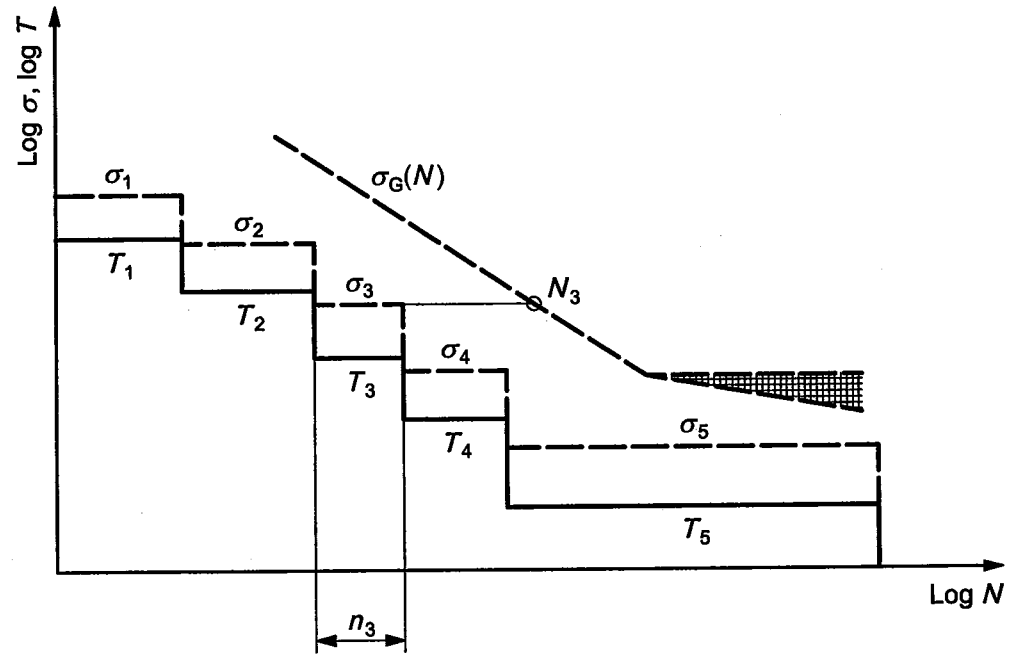

NOTE 1 The representation of the cumulative stress spectrum entirely below the S-N curve does not imply that the part will survive the total accumulative number of stress cycles. This information can be gained from a presentation as shown in Figure 3.

NOTE 2 The value σ_G is either σ_{HG} or σ_{FG} .

Figure 2 — Torque spectrum and associated stress spectrum with S-N

The stress spectra for tooth root and tooth flank (σ_{Fi} , σ_{Hi}) with all relative factors are formed on the basis of this torque spectrum. The load-dependent K-factors are calculated for each new torque class (for the procedure, see 5.2).

With stress spectra obtained in this way, the calculated values are compared with the strength values (S-N curves, damage line) determined according to 5.3 using the Palmgren-Miner rule, see 4.3. For a graphical representation, see Figure 3.

For all values of σ_i , individual damage parts are defined as follows:

$$U_i = \frac{n_i}{N_i} \tag{2}$$

The sum of the individual damage parts, U_i , results in the damage condition U , which must be less than or equal to unity.

$$U = \sum_i U_i = \sum_i \frac{n_i}{N_i} \leq 1,0 \tag{3}$$

NOTE The calculation of speed-dependent parameters is based, for each load level, on a mean rotational speed. This also refers to the determination of the S-N curve.

This calculation process shall be applied to each pinion and wheel for both bending and contact stress.

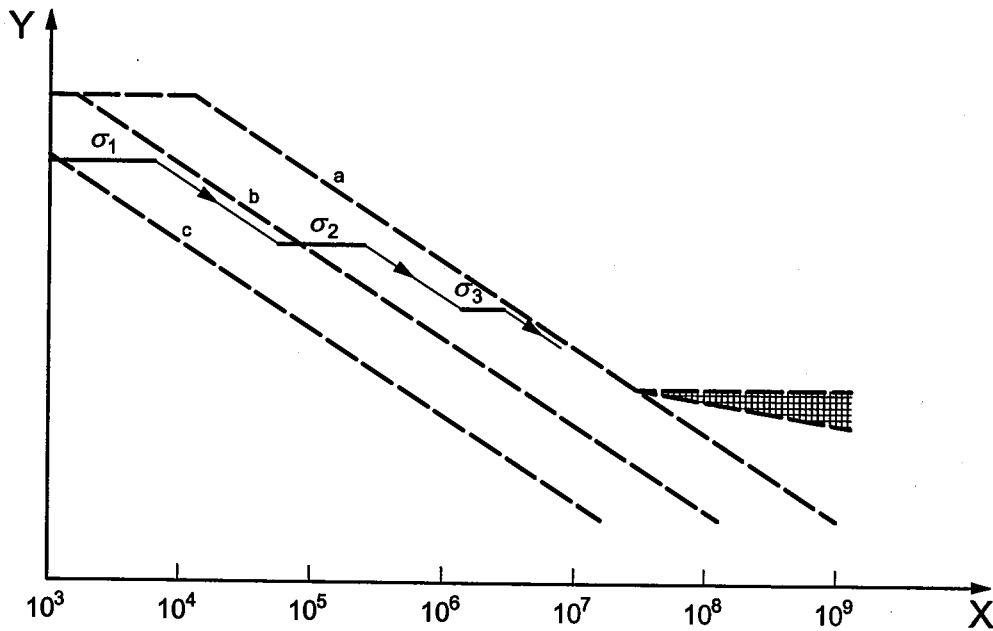

Key

X number of load cycles, N_L
Y stress

NOTE From this presentation it can be concluded whether the part will survive the total number of stress cycles.

- a 100 % damage.
- b 10 % de damage.
- c 1 % de damage.

Figure 3 — Accumulation of damage

In addition, safety factors applied to static load strength should be calculated for the highest stress of the design life. ISO 6336 does not extend to stress levels greater than those permissible at 10^3 cycles or less, since stresses in this range can exceed the elastic limit of the gear tooth in bending or in surface compression. In addition, safety factors applied to the static load strength should be calculated for the highest stress of the design life. The highest stress could be either the maximum stress in the load spectrum or an extreme transient load that is not considered in the fatigue analysis. Depending on the material and the load imposed, a single stress cycle greater than the limit level at $< 10^3$ cycles could result in plastic yielding of the gear tooth.

5.2 Calculation of stress spectra

For each level i of the torque spectrum, the actual stress, σ_i , is to be determined separately for contact and bending stress in accordance with the following equations.

— For contact stress (ISO 6336-2:2006, Method B):

$$\sigma_{Hi} = Z_H Z_E Z_\epsilon Z_\beta Z_{BD} \sqrt{\frac{2000 T_i}{d_1^2 b} \frac{u+1}{u}} K_{vi} K_{H\beta i} K_{H\alpha i} \quad (4)$$

— For bending stress (ISO 6336-3:2006, Method B):

$$\sigma_{Fi} = \frac{2000 T_i}{d_1 b m_n} Y_F Y_S Y_\beta K_{vi} K_{F\beta i} K_{F\alpha i} \quad (5)$$

The value K_A , defined as application factor, is set equal to unity (1,0) for this calculation, as all the application load influences should be taken into account by stress levels included in the calculation method.

5.3 Determination of pitting and bending strength values

S-N curves for pitting and bending strength can be determined by experiment or by the rules of ISO 6336-2 and ISO 6336-3.

Where teeth are loaded in both directions (e.g. idler gear), the values determined for tooth root strength must be reduced according to ISO 6336-3.

Reverse torques affects the contact stress spectrum of the rear flank. Damage accumulation has to be considered separately for each flank side.

5.4 Determination of safety factors

In the general case, safety factors cannot directly be deduced from the Miner sum, U . They are to be determined by way of iteration. The procedure is shown in Figure 4.

The safety factor, S , has to be calculated separately for the pinion and the wheel, each for both bending and pitting. The safety factor is only valid for the required life used for each calculation. Annex C shows an example for calculating S .

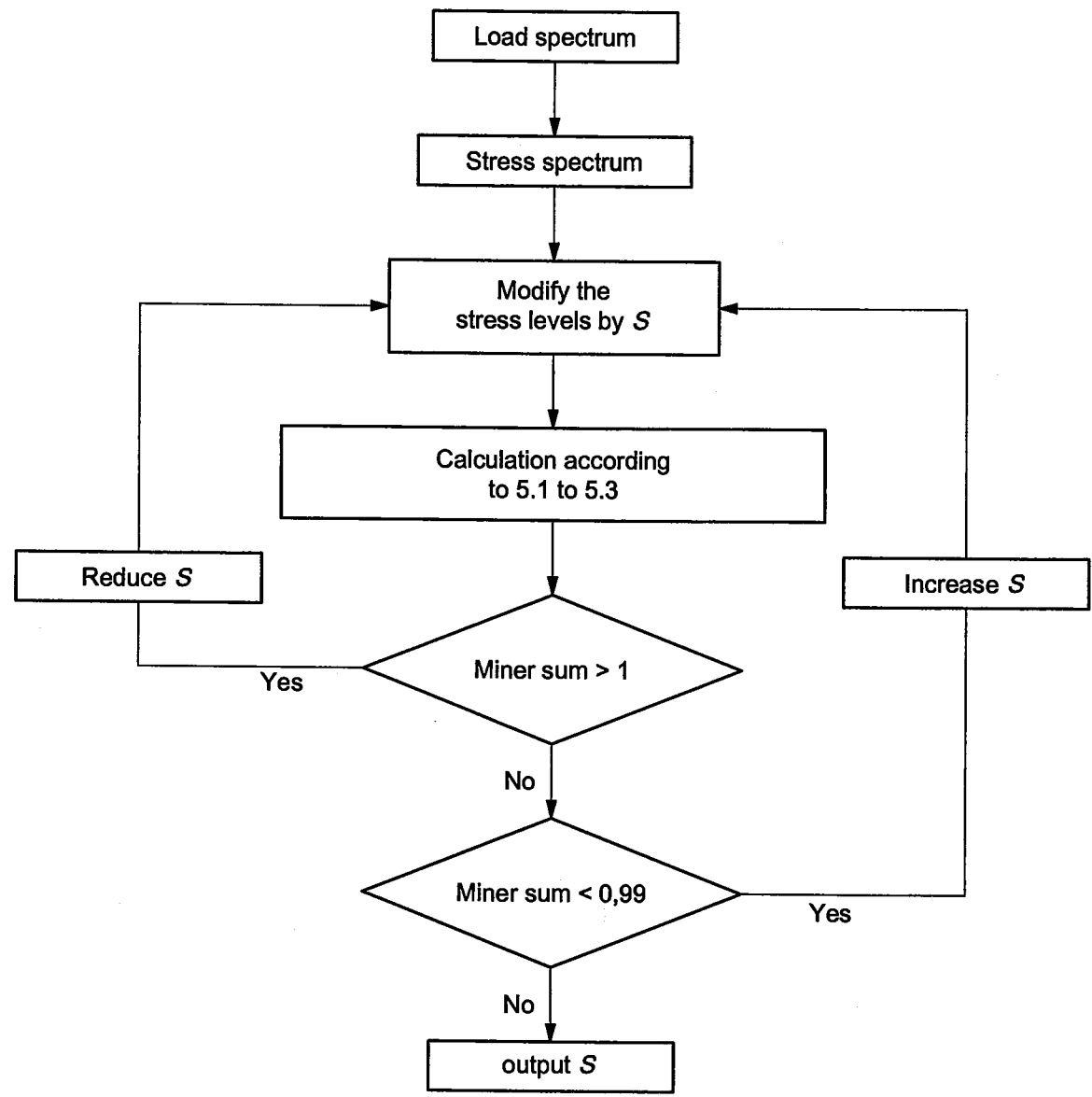

Figure 4 — Flow chart for determination of calculated safety factor for given load spectrum

Annex A (normative)

Determination of application factor, K_A , from given load spectrum using equivalent torque, T_{eq}

A.1 Purpose

A calculation of application factor K_A for a given load spectrum is allowed if agreed between purchaser and gear box manufacturer. This calculation method is useful for a first estimation during the gear design stage, where the geometry data of a gear drive is not fixed.

A.2 Application factor, K_A

The application factor K_A is defined as the ratio between the equivalent torque and the nominal torque:

$$K_A = \frac{T_{eq}}{T_n} \quad (\text{A.1})$$

where

T_n is the nominal torque;

T_{eq} is the equivalent torque.

Application factor K_A has to be determined for tooth root breakage and pitting resistance, both for pinion and wheel. The highest of these four values has to be used for a gear rating in conformance with ISO 6336.

The equivalent torque is defined by Equation (A.2):

$$T_{eq} = \left(\frac{n_1 T_1^p + n_2 T_2^p + \dots}{n_1 + n_2 + \dots} \right)^{\frac{1}{p}} \quad (\text{A.2})$$

where

n_i is the number of cycles for bin i ;

T_i is the torque for bin i ;

p is the slope of the Woehler-damage line, see Table A.1.

The slope of the damage lines used by ISO 6336 means that the number of bins to be used in Equation (A.2) cannot be predetermined. Therefore, the procedure described in A.2.2 shall be used in place of Equation (A.2).

A.3 Determination of the equivalent torque, T_{eq}

For this procedure, the load spectrum, the slopes of the Woehler-damage lines, p , and the number of load cycles, $N_{L,ref}$, at the reference point must be known.

A.3.1 Basis

The following method applies for a design case where the Woehler-damage line is simplified by ignoring all damage which occurs at stresses below some limit stress. It is based upon the fact that while the position of the endurance limit in terms of stress is not known in relation to the gear until the design is available, the position of that endurance limit in terms of cycles does not change as the gear design changes.

Further on, a torque T_i in the bin i can be replaced by a torque T_j in a new bin, j , so that the damage caused by the torque T_i is the same as that caused by the torque T_j . This is shown in Figure A.1 and can be expressed by Equation (A.3).

$$T_i^P n_i = T_j^P n_j \quad (\text{A.3})$$

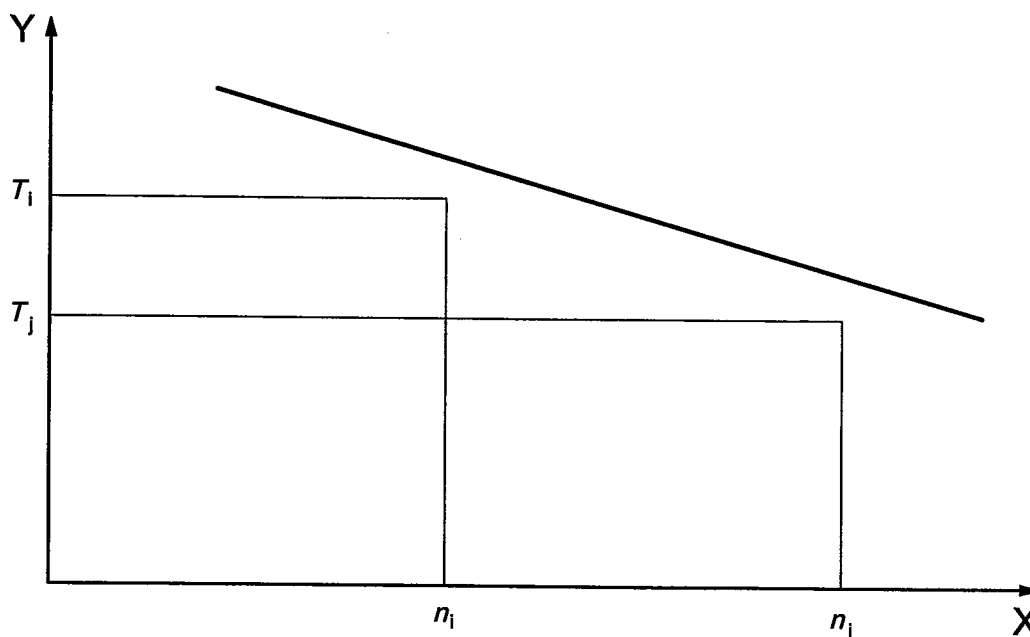

Key

- X number of load cycles, n_L
- Y torque, T

Figure A.1 — Load bins with equal damage behaviour according to Equation (A.3)

A.3.2 Calculation procedure

The load bins have to be denoted as (T_i, n_i) and numbered in descending order of torque, where T_1 is the highest torque. Then the cycles n_1 at torque T_1 are equivalent in terms of damage to a larger number of cycles n_{1a} , at lower torque T_2 , where, according to Equation (A.3):

$$n_{1a} = n_1 \left(\frac{T_1}{T_2} \right)^P \quad (\text{A.4})$$

If $n_{2e} = n_2 + n_{1a}$, then bins 1 and 2 can be replaced by a single bin (T_2, n_{2e}) , see Figure A.2.

Similarly, the cycles n_{2e} at torque T_2 are equivalent to n_{2a} at T_3 , where

$$n_{2a} = n_{2e} \left(\frac{T_2}{T_3} \right)^p \quad (\text{A.5})$$

Writing $n_{3e} = n_3 + n_{2a}$, then bins 1, 2 and 3 can be replaced by a single bin (T_3, n_{3e}) .

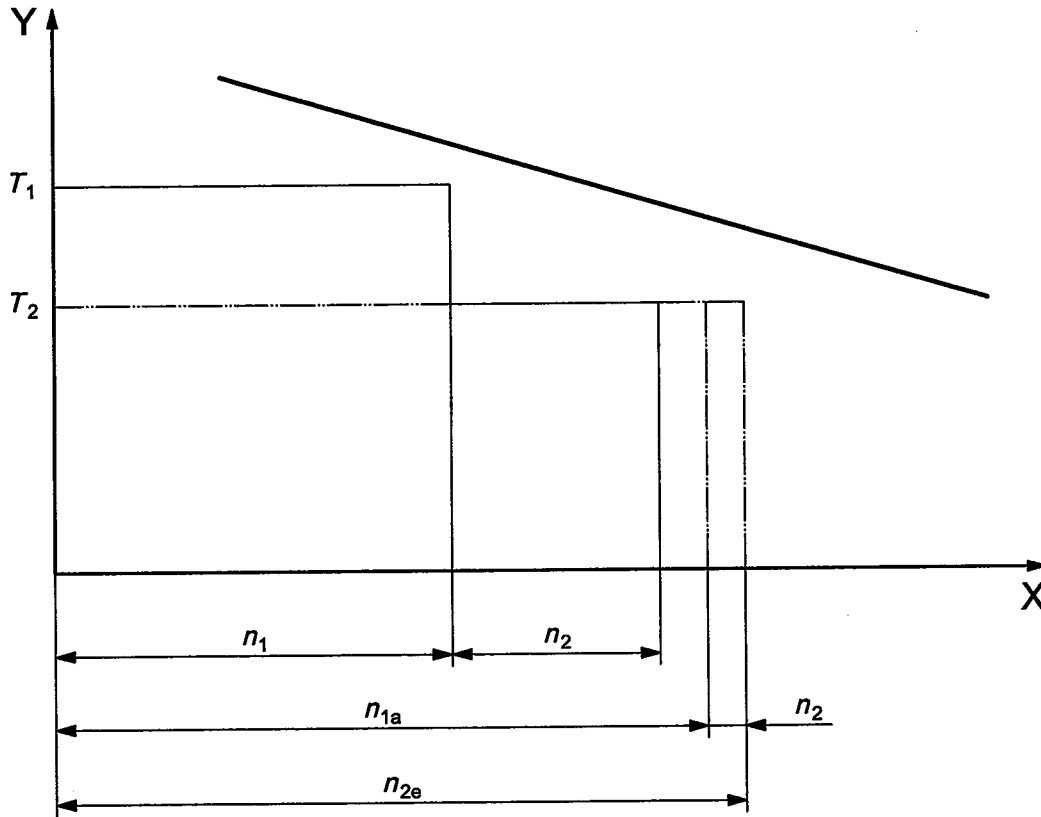

Key

- X number of load cycles, n_L
- Y torque, T

Figure A.2 — Bins (T_1, n_1) and (T_2, n_2) replaced by (T_{2e}, n_{2e})

This procedure has to be stopped when n_{ie} reaches the endurance limit cycles, $N_{L \text{ ref}}$.

The required equivalent torque T_{eq} is now bracketed:

$$T_i < T_{eq} < T_{i-1} \quad (\text{A.6})$$

or

$$\frac{T_i}{T_n} < K_A < \frac{T_{i-1}}{T_n} \quad (\text{A.7})$$

and can be found by linear interpolation on a log-log basis.

The slope exponent, p , and the endurance limit cycles, N_L , are a function of the heat treatment. Values to be used in Equations (A.4) and (A.5) are shown in Table A.1.

Table A.1 — Exponent p and number of load cycles $N_{L\text{ref}}$

Heat treatment	Pitting		Tooth root	
	p^a	$N_{L\text{ref}}$	p	$N_{L\text{ref}}$
Case carburized	6,610	5×10^7	8,738	3×10^6
Through hardened	6,610	5×10^7	6,225	3×10^6
Nitrided	5,709	2×10^6	17,035	3×10^6
Nitro-carburized	15,715	2×10^6	84,003	3×10^6

^a Values p for pitting are given for torque; to convert for stress, these values are to be doubled.

A.4 Example

An example is shown in Figure A.3 and the corresponding Table A.2. In the right hand column of the table a switch is shown that indicates when the endurance limit has been reached. In this example application factor K_A is between 1,16 and 1,18. From the fact that on row 12 the value of n_{ie} is very close to the endurance limit, the interpolation will give $K_A = 1,18$.

It is important to note that this value of K_A should only be used with the same nominal torque used ($950 \text{ kN} \cdot \text{m}$) and with the life factors which match the endurance limit cycles used ($5,0 \times 10^7$), when doing the gear design.

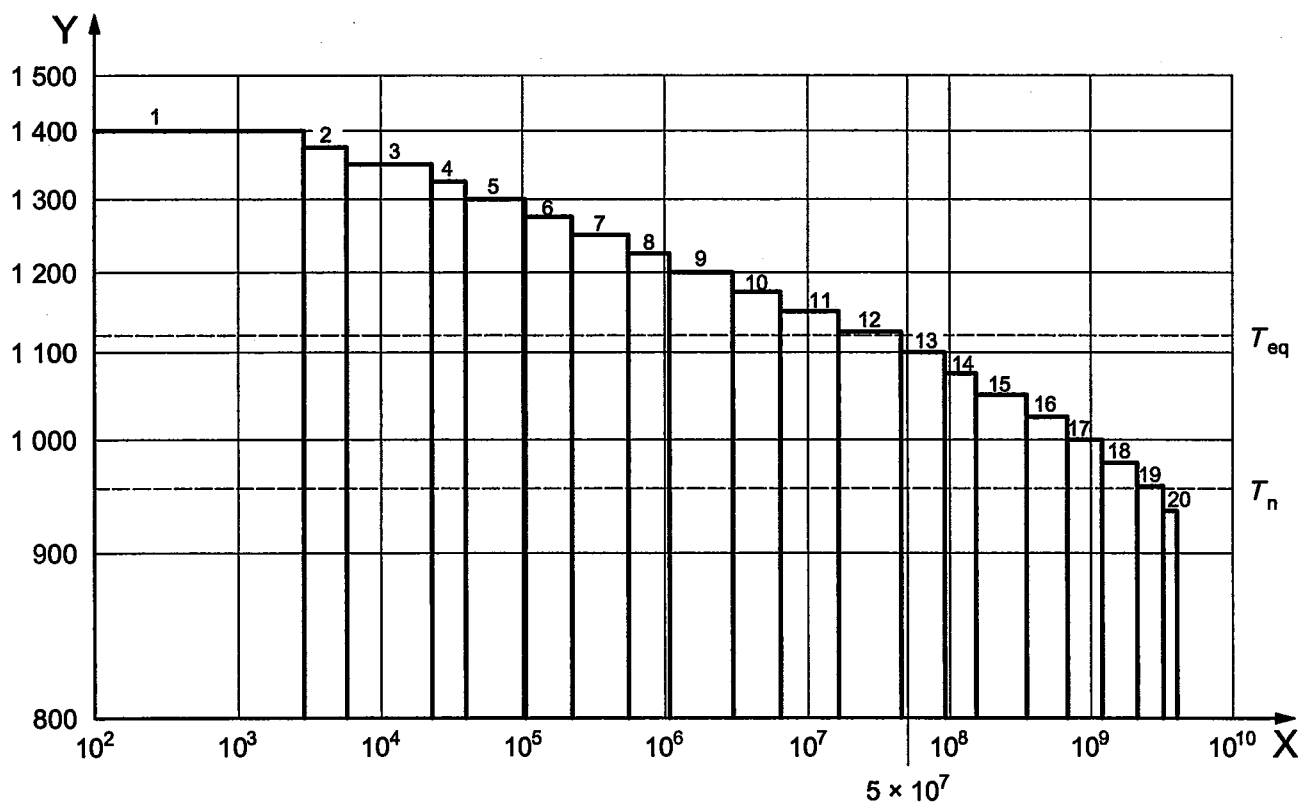

Key

- X number of load cycles, N_L
- Y couple T , kN·m

Figure A.3 — Load spectrum with corresponding equivalent torque, T_{eq}

Table A.2 — Example for calculation of K_A from load spectrum

Cumulative damage/calculation of K_A							
Flank				Nominal torque $T_n = 950$ kN·m			
Ratio to this gear $u = 75$				Blade speed $n_b = 20$ r/min			
Contacts per revolution = 1				Slope exponent $p = 6,6$			
Speed = 1 500 stress cycles/min				Endurance limit cycles $N_{L,ref} = 5,00e+07$			
Bin <i>i</i>	Blade torque T_i	Torque ratio T_i/T_n	<i>h</i> <i>L</i>	Cycles n_i	Equivalent from row above n_{ia}	Total n_{ie}	Switch
1	1 400	1,47	0,032	2 880	—	2 880	0
2	1 375	1,45	0,032	2 880	3 240	6 120	0
3	1 350	1,42	0,190	17 100	6 910	24 000	0
4	1 325	1,39	0,183	16 500	27 200	43 600	0
5	1 300	1,37	0,708	63 700	49 500	113 000	0
6	1 275	1,34	1,30	117 000	129 000	246 000	0
7	1 250	1,32	3,70	333 000	280 000	613 000	0
8	1 225	1,29	5,80	522 000	700 000	1 220 000	0
9	1 200	1,26	21	1 890 000	1 400 000	3 290 000	0
10	1 175	1,24	38	3 420 000	3 780 000	7 200 000	0
11	1 150	1,21	110	9 900 000	8 300 000	18 200 000	0
12	1 125	1,18	320	28 800 000	21 000 000	49 800 000	0
13	1 100	1,16	520	46 800 000	57 800 000	105 000 000	1
14	1 075	1,13	700	63 000 000	122 000 000	185 000 000	1
15	1 050	1,11	2 200	198 000 000	216 000 000	414 000 000	1
16	1 025	1,08	3 700	333 000 000	485 000 000	818 000 000	1
17	1 000	1,05	5 800	522 000 000	963 000 000	1 480 000 000	1
18	975	1,03	10 200	918 000 000	1 760 000 000	2 670 000 000	1
19	950	1,00	12 400	1 120 000 000	3 170 000 000	4 290 000 000	1
20	925	0,97	9 100	819 000 000	5 110 000 000	5 930 000 000	1

Annex B (informative)

Guide values for application factor, K_A

The application factor, K_A , is used to modify the value of F_t to take into account loads, additional to nominal loads, which are imposed on the gears from external sources. The empirical guidance values given in Table B.1 can be used (for industry gears and high speed gears).

Table B.1 — Application factor, K_A

Working characteristic of driving machine	Working characteristic of driven machine			
	Uniform	Light shocks	Moderate shocks	Heavy shocks
Uniform	1,00	1,25	1,50	1,75
Light shocks	1,10	1,35	1,60	1,85
Moderate shocks	1,25	1,50	1,75	2,00
Heavy shocks	1,50	1,75	2,00	≥ 2,25

The value of K_A is applied to the nominal torque of the machine under consideration. Alternatively, it may be applied to the nominal torque of the driving motor as long as this corresponds to the torque demand of the driving machine.

The values only apply to transmissions, which operate outside the resonance speed range under relatively steady loading. If operating conditions involve unusually heavy loading, motors with high starting torques, intermittent service or heavy repeated shock loading, or service brakes with a torque greater than the driving-motor, the safety of the static and limited life gear load capacity shall be verified (see ISO 6336-1, ISO 6336-2 and ISO 6336-3).

EXAMPLE 1 Turbine/generator: in this system, short-circuit torque of up to 6 times the nominal torque can occur. Such overloads can be shed by means of safety couplings.

EXAMPLE 2 Electric motor/compressor: if pump frequency and torsional natural frequency coincide, considerable alternating stresses can occur.

EXAMPLE 3 Heavy plate and billet rolling mills: initial pass-shock-torque up to 6 times the rolling torque can occur.

EXAMPLE 4 Drives with synchronous motors: alternating torque up to 5 times the nominal torque can occur briefly (approximately 10 amplitudes) on starting; however, hazardous alternating torque can often be completely avoided by the appropriate detuning measures.

Information and numerical values provided here cannot be generally applied. The magnitude of the peak torque depends on the mass spring system, the forcing term, safety precautions (safety coupling, protection for unsynchronized switching of electrical machines), etc.

Thus, in critical cases, careful analysis should be demanded. It is then recommended that agreement be reached on suitable actions.

If special application factors are required for specific purposes, these shall be applied (e.g. because of a variable duty list specified in the purchase order, for marine gears according to the rules of a classification authority).

Where there are additional inertial masses, torques resulting from the flywheel effect are to be taken into consideration. Occasionally, braking torque provides the maximum loading and thus influences calculation of load capacity.

It is assumed the gear materials used will have adequate overload capacity. When materials used have only marginal overload capacity, designs should be laid out for endurance at peak loading.

The K_A value for light, moderate and heavy shocks can be changed by using hydraulic couplings or torque matched elastic couplings, and especially vibration attenuating couplings when the characteristics of the couplings permit.

Table B.2 — Examples for driving machines with various working characteristics

Working characteristic	Driving machine
Uniform	Electric motor (e.g. d.c. motor), steam or gas turbine with uniform operation ^a and small rarely occurring starting torques ^b .
Light shocks	Steam turbine, gas turbine, hydraulic or electric motor (large, frequently occurring starting torques ^b).
Moderate shocks	Multiple cylinder internal combustion engines.
Heavy shocks	Single cylinder internal combustion engines.
^a Based on vibration tests or on experience gained from similar installations. ^b See service life graphs, Z_{NT} , Y_{NT} , for the material in ISO 6336-2 and ISO 6336-3. Consideration of momentarily acting overload torques, see examples following Table B.1.	

Table B.3 — Industrial gears — Examples of working characteristics of driven machine

Working characteristic	Driven machines
Uniform	Steady load current generator; uniformly loaded conveyor belt or platform conveyor; worm conveyor; light lifts; packing machinery; feed drives for machine tools; ventilators; light-weight centrifuges; centrifugal pumps; agitators and mixers for light liquids or uniform density materials; shears; presses, stamping machines ^a ; vertical gear, running gear ^b .
Light shocks	Non-uniformly (i.e. with piece or batched components) loaded conveyor belts or platform conveyors; machine-tool main drives; heavy lifts; crane slewing gear; industrial and mine ventilators; heavy centrifuges; centrifugal pumps; agitators and mixers for viscous liquids or substances of non-uniform density; multi-cylinder piston pumps; distribution pumps; extruders (general); calendars; rotating kilns; rolling mill stands ^c , (continuous zinc and aluminium strip mills, wire and bar mills).
Moderate shocks	Rubber extruders; continuously operating mixers for rubber and plastics; ball mills (light); wood-working machines (gang saws, lathes); billet rolling mills ^{c, d} ; lifting gear; single cylinder piston pumps.
Heavy shocks	Excavators (bucket wheel drives); bucket chain drives; sieve drives; power shovels; ball mills (heavy); rubber kneaders; crushers (stone, ore); foundry machines; heavy distribution pumps; rotary drills; brick presses; de-barking mills; peeling machines; cold strip ^{c, e} ; briquette presses; breaker mills.
^a Nominal torque = maximum cutting, pressing or stamping torque. ^b Nominal torque = maximum starting torque. ^c Nominal torque = maximum rolling torque. ^d Torque from current limitation. ^e K_A up to 2,0 because of frequent strip cracking.	

Table B.4 — High speed gears and gears of similar requirement — Examples of working characteristics of driven machines

Working characteristic	Driven machine
Uniform	Centrifugal compressors for air conditioning installation, for process gas; dynamometer — test rig; base or steady load generator and exciter; paper machinery main drives.
Moderate shocks	Centrifugal compressors for air or pipelines; axial compressors; centrifugal fans; peak load generators and exciters; centrifugal pumps (all types other than those listed below); axial-flow rotary pumps; paper industry; Jordan or refining machine, machines, machine auxiliary drives, stamper.
Medium shocks	Rotary-cam blower; rotary-cam compressor with radial flow; piston compressor (3 or more cylinders); ventilator suction-fans, mining and industrial (large, frequent start-up cycles); centrifugal boiler-feed pumps; rotary cam pumps, piston pumps (3 or more cylinders).
Heavy shocks	Piston compressor (2 cylinders); centrifugal pump (with water tank); sludge pump; piston pump (2 cylinders).

Annex C (informative)

Example calculation of safety factor from given load spectrum

C.1 Background

The example is from a forty-ton container crane boom hoist. This uses the same load spectrum found in Table 2. More specifically, the example is a gear mesh in a reducer, which drives a winch drum for the boom hoist, which raises and lowers the boom for the container crane. This is done via pulleys and a pivot.

The boom is supported by folding support rods when the boom is all the way down (and the crane is in use). The winch must raise the boom out of the way when the crane is not in use, or to allow ships to move past the crane. Similarly, there is a support that locks the boom upright, once it is completely raised.

The pulley system involves multiple wraps of cable, for a mechanical advantage. The load is constantly varying, since the centre of gravity of the boom changes with respect to the pivot and the angle of the cable changes.

There are load variations from accelerations and decelerations at the start and end of travel. Wind, rain and ice build-up can also change the loading.

This boom hoist uses a four-stage reduction gearbox, with a 175,3:1 overall ratio. This example is for the pinion of the fourth reduction low speed mesh, with the geometry, as given in Table C.1.

Table C.1 — Geometry data of the example

Item	Pinion	Wheel	Unit
No. of teeth, z	17	60	—
Gear ratio, u	3,529 41		mm
Normal module, m_n	8,467		°
Normal pressure angle, α	25		°
Helix angle, β	15,5		mm
Centre distance, a	339,727		mm
Face width, b	152,4		mm
Tip diameter, d_a	169,212	544,132	mm
Profile shift coefficient, x	0,172 0	0,001 5	—

The set is carburized and ground, MQ, accuracy grade ISO 6, cutter addendum is $1,35 \times m_n$, with a full tip radius, zero protuberance and zero grind stock.

C.2 Define load spectrum

The load spectrum can be found in Table 2. In this case, the boom was raised and lowered 10 times, to simulate 70 days of loading. The pinion speed is 35,2 r/min.

This spectrum has 48 bins, but the first two bins (Nos. 1 and 2) have no load cycles. This is acceptable, as it is important that the spectrum loads are large enough to include the highest loads the gears will see. Similarly bins No. 45 to No. 47 have no load cycles. This is because the mesh is always under some load, until the weight of the boom is transferred to either the support rods or the support that locks the boom upright.

The last load bin (No. 48) is purposely set to zero load and cycles, but with a specific time interval. This bin is meant to account for the time when there is no load on the mesh. This bin is used to clarify the elapse time period of the sample load spectrum, i.e.

$$6\,048\,000 \text{ seconds} = 100\,800 \text{ minutes} = 1\,680 \text{ hours} = 70 \text{ days} = 0,191\,8 \text{ years},$$

since the gears are unloaded for a significant amount of time. (99,891 9 % of the time).

The desired useful life (30 years) is longer than the spectrum (70 days). So each bin's load cycles will need to be scaled up by a factor of $156,53 = (30 \times 365,25/70)$.

C.3 Check for plastic yielding

Using the highest load bin in the spectrum (bin No. 3), calculate the safety factor for 10^3 cycles, using ISO 6336-2:2006, Equation (14), and ISO 6336-3:2006, Equation (7). This must be done to ensure the gears will not fail by plastic yielding (see 5.1).

$$S_H = \frac{\sigma_{HP}}{\sigma_H} = \frac{2\,400 \text{ N/mm}^2}{1\,747 \text{ N/mm}^2} = 1,374$$

$$S_F = \frac{\sigma_{FP}}{\sigma_F} = \frac{2\,356 \text{ N/mm}^2}{826 \text{ N/mm}^2} = 2,852$$

C.4 Calculate the stress spectra

For each load bin in the spectrum (Nos. 3 to 44), calculate the bending and contact stress in accordance with Equations (4) and (5) of this part of ISO 6336. The values are given in Tables C.2 and C.3.

C.5 Calculate strength values

Using the nominal load conditions, calculate the permissible bending and contact stresses for unity values of life factors in accordance with ISO 6336-2:2006, Equation (6), and ISO 6336-3:2006, Equation (5).

$$\sigma_{HP} = \frac{\sigma_{Hlim} Z_L Z_v Z_R Z_W Z_X}{S_{Hmin}}$$

$$\sigma_{HP} = \frac{1\,500 \text{ N/mm}^2 \times 1,02 \times 0,943 \times 1,01 \times 1 \times 1}{1,0} = 1\,457 \text{ N/mm}^2$$

$$\sigma_{FP} = \frac{\sigma_{Flim} Y_{ST} Y_{\delta rel T} Y_{R rel T} Y_X}{S_{Fmin}}$$

$$\sigma_{FP} = \frac{461 \text{ N/mm}^2 \times 2,0 \times 1,0 \times 1,054 \times 0,967}{1,0} = 940 \text{ N/mm}^2$$

C.6 Calculate damage parts of spectra

For each load bin in the spectrum (bin Nos. 3 to 44), calculate the damage part, U_i . The method is the same for both bending and contact stress. Reference: Equation (2) of this part of ISO 6336; ISO 6336-2:2006, Figure 6, and ISO 6336-3:2006, Figure 9). Exponents are determined from method given in ISO 6336-2:2006, 5.3.3.2, and ISO 6336-3:2006, 5.3.3.2. The number of cycles, n_i , must be for the complete operating life, not just for the 70 days worth of load cycles measured, as described in C.2. The values are given in Tables C.2 and C.3.

— For contact stress:

$$Z_{NTi} = \frac{\sigma_{Hi}}{\sigma_{HPi}}$$

$$N_i = \left(\frac{Z_{NTi}}{1,6} \right)^{13,222\ 469} \times 10^5 \text{ (if } Z_{NTi} > 1), N_i = (Z_{NTi})^{32,601\ 229\ 26} \times 5 \times 10^5 \text{ (if } Z_{NTi} \leq 1)$$

$$U_i = \frac{n_i}{N_{ii}}$$

— For bending stress:

$$Y_{NTi} = \frac{\sigma_{Fi}}{\sigma_{FPI}}$$

$$N_i = \left(\frac{Y_{NTi}}{2,5} \right)^{8,737\ 249\ 08} \times 10^3 \text{ (if } Y_{NTi} \geq 1), N_i = (Y_{NTi})^{49,912\ 503\ 38} \times 3 \times 10^6 \text{ (if } Y_{NTi} < 1)$$

$$U_i = \frac{n_i}{N_{ii}}$$

C.7 Calculate the Miner sum

Sum up each damage part of the spectra according to Equation (3). The values are given at the foot of Tables C.2 and C.3.

C.8 Iterate the safety factor

Following Figure 7, by iterating, change the safety factor up or down as needed and recalculate according to C.4 to C.7 until the sum of damage parts, U_i , is between 0,99 and 1,00. For this example, the spreadsheet program function was used to do the iterations. For 30 years of operation, this pinion has a safety factor of 1,428 in pitting and a safety factor of 1,324 in bending.

The values are given in Tables C.2 and C.3.

Table C.2 — Example for calculation of pitting safety factor from load spectrum safety factor = 1,428

Bin No.	Pinion torque T_1 kN·m	Time over 70 days s	Pinion speed n_1 r/min	Stress cycles in 30 years N	Face load factor $K_{H\beta}$	Contact stress $\sigma_H \cdot S_H$ N/mm ²	Life factor Z_{NT}	Cycles to failure N_f	Damage parts U_i (N/N_f)
1	25,6	0,00E+00	35,2	0,000E+00					0,000E+00
2	25,5	0,00E+00	35,2	0,000E+00					0,000E+00
3	25,4	2,40E+01	35,2	2,203E+03	1,305	2 350	1,613	8,990E+04	2,450E-02
4	25,3	1,40E+01	35,2	1,285E+03	1,305	2 347	1,610	9,172E+04	1,401E-02
5	25,3	9,00E+00	35,2	8,259E+02	1,305	2 343	1,608	9,361E+04	8,824E-03
6	25,2	1,40E+01	35,2	1,285E+03	1,305	2 340	1,606	9,551E+04	1,345E-02
7	25,1	2,80E+01	35,2	2,570E+03	1,305	2 336	1,603	9,749E+04	2,636E-02
8	25,0	1,40E+01	35,2	1,285E+03	1,305	2 332	1,600	9,970E+04	1,289E-02
9	24,9	9,00E+00	35,2	8,259E+02	1,305	2 328	1,597	1,022E+05	8,083E-03
10	24,8	1,90E+01	35,2	1,744E+03	1,305	2 323	1,594	1,050E+05	1,661E-02
11	24,7	2,80E+01	35,2	2,570E+03	1,305	2 318	1,591	1,080E+05	2,378E-02
12	24,6	3,30E+01	35,2	3,028E+03	1,305	2 312	1,587	1,115E+05	2,717E-02
13	24,5	2,40E+01	35,2	2,203E+03	1,305	2 306	1,583	1,155E+05	1,907E-02
14	24,3	2,40E+01	35,2	2,203E+03	1,305	2 299	1,578	1,202E+05	1,832E-02
15	24,2	1,90E+01	35,2	1,744E+03	1,305	2 292	1,573	1,256E+05	1,388E-02
16	24,0	2,60E+01	35,2	2,386E+03	1,305	2 283	1,567	1,320E+05	1,808E-02
17	23,8	5,20E+01	35,2	4,772E+03	1,305	2 274	1,560	1,392E+05	3,428E-02
18	23,6	4,70E+01	35,2	4,313E+03	1,305	2 264	1,553	1,479E+05	2,916E-02
19	23,3	6,20E+01	35,2	5,690E+03	1,305	2 252	1,545	1,583E+05	3,595E-02
20	23,1	8,80E+01	35,2	8,076E+03	1,305	2 239	1,537	1,706E+05	4,734E-02
21	22,8	6,60E+01	35,2	6,057E+03	1,305	2 225	1,527	1,853E+05	3,268E-02
22	22,5	1,63E+02	35,2	1,496E+04	1,305	2 210	1,517	2,029E+05	7,373E-02
23	22,1	1,80E+02	35,2	1,652E+04	1,305	2 193	1,505	2,245E+05	7,359E-02
24	21,8	8,30E+01	35,2	7,617E+03	1,305	2 174	1,492	2,511E+05	3,034E-02
25	21,4	2,00E+02	35,2	1,835E+04	1,305	2 155	1,479	2,841E+05	6,461E-02
26	20,9	2,12E+02	35,2	1,946E+04	1,305	2 133	1,463	3,254E+05	5,979E-02
27	20,5	1,04E+02	35,2	9,544E+03	1,305	2 109	1,447	3,775E+05	2,528E-02
28	20,0	2,38E+02	35,2	2,184E+04	1,305	2 083	1,429	4,452E+05	4,907E-02
29	19,4	2,53E+02	35,2	2,322E+04	1,305	2 054	1,410	5,342E+05	4,346E-02
30	18,8	2,00E+02	35,2	1,835E+04	1,305	2 023	1,388	6,530E+05	2,811E-02
31	18,2	2,06E+02	35,2	1,890E+04	1,305	1 989	1,365	8,148E+05	2,320E-02
32	17,6	2,97E+02	35,2	2,726E+04	1,305	1 953	1,340	1,040E+06	2,622E-02
33	16,9	3,16E+02	35,2	2,900E+04	1,305	1 914	1,313	1,363E+06	2,128E-02
34	16,1	3,34E+02	35,2	3,065E+04	1,305	1 870	1,284	1,843E+06	1,663E-02
35	15,3	3,52E+02	35,2	3,230E+04	1,305	1 823	1,251	2,580E+06	1,252E-02
36	14,5	2,74E+02	35,2	2,515E+04	1,320	1 783	1,223	3,480E+06	7,225E-03
37	13,6	2,86E+02	35,2	2,625E+04	1,341	1 740	1,194	4,776E+06	5,496E-03
38	12,6	4,04E+02	35,2	3,708E+04	1,367	1 695	1,163	6,796E+06	5,456E-03
39	11,6	4,29E+02	35,2	3,937E+04	1,398	1 645	1,129	1,009E+07	3,903E-03
40	10,6	4,49E+02	35,2	4,121E+04	1,438	1 591	1,091	1,572E+07	2,622E-03
41	9,5	4,68E+02	35,2	4,295E+04	1,489	1 531	1,051	2,594E+07	1,656E-03
42	8,3	3,03E+02	35,2	2,781E+04	1,558	1 467	1,007	4,583E+07	6,067E-04
43	7,1	1,76E+02	35,2	1,615E+04	1,655	1 396	0,958	2,046E+08	7,894E-05
44	5,8	1,20E+01	35,2	1,101E+03	1,800	1 317	0,903	1,368E+09	8,049E-07
45	4,4	0,00E+00	35,2	0,000E+00					0,000E+00
46	3,0	0,00E+00	35,2	0,000E+00					0,000E+00
47	1,6	0,00E+00	35,2	0,000E+00					0,000E+00
48	0,0	6,04E+06	0	0,000E+00					0,000E+00
Total				6,001E+05				Miner sum	9,993E-01
Pitting life				6,001E+05 cycles = 2,632E+05 hours = 3,002E+01 years					

Table C.3 — Example for calculation of bending safety factor from load spectrum safety factor = 1,324

Bin No.	Pinion torque T_1 kN·m	Time over 70 days s	Pinion speed n_1 r/min	Stress cycles in 30 years N	Face load factor $K_{F\beta}$	Bending stress $\sigma_F \cdot S_F$ N/mm ²	Life factor Y_{NT}	Cycles to failure N_f	Damage parts U_i (N/N_i)
1	25,6	0,00E+00	35,2	0,000E+00					0,000E+00
2	25,5	0,00E+00	35,2	0,000E+00					0,000E+00
3	25,4	2,40E+01	35,2	2,203E+03	1,261	1 458	1,551	6,470E+04	3,404E-02
4	25,3	1,40E+01	35,2	1,285E+03	1,261	1 453	1,547	6,644E+04	1,934E-02
5	25,3	9,00E+00	35,2	8,259E+02	1,261	1 449	1,542	6,825E+04	1,210E-02
6	25,2	1,40E+01	35,2	1,285E+03	1,261	1 444	1,537	7,010E+04	1,833E-02
7	25,1	2,80E+01	35,2	2,570E+03	1,261	1 440	1,532	7,202E+04	3,568E-02
8	25,0	1,40E+01	35,2	1,285E+03	1,261	1 435	1,527	7,419E+04	1,732E-02
9	24,9	9,00E+00	35,2	8,259E+02	1,261	1 430	1,521	7,664E+04	1,078E-02
10	24,8	1,90E+01	35,2	1,744E+03	1,261	1 424	1,515	7,941E+04	2,196E-02
11	24,7	2,80E+01	35,2	2,570E+03	1,261	1 418	1,509	8,249E+04	3,115E-02
12	24,6	3,30E+01	35,2	3,028E+03	1,261	1 411	1,502	8,598E+04	3,522E-02
13	24,5	2,40E+01	35,2	2,203E+03	1,261	1 404	1,494	9,009E+04	2,445E-02
14	24,3	2,40E+01	35,2	2,203E+03	1,261	1 395	1,485	9,499E+04	2,319E-02
15	24,2	1,90E+01	35,2	1,744E+03	1,261	1 386	1,475	1,007E+05	1,732E-02
16	24,0	2,60E+01	35,2	2,386E+03	1,261	1 375	1,464	1,075E+05	2,220E-02
17	23,8	5,20E+01	35,2	4,772E+03	1,261	1 364	1,452	1,153E+05	4,138E-02
18	23,6	4,70E+01	35,2	4,313E+03	1,261	1 352	1,439	1,249E+05	3,453E-02
19	23,3	6,20E+01	35,2	5,690E+03	1,261	1 338	1,424	1,367E+05	4,164E-02
20	23,1	8,80E+01	35,2	8,076E+03	1,261	1 323	1,408	1,509E+05	5,352E-02
21	22,8	6,60E+01	35,2	6,057E+03	1,261	1 307	1,390	1,683E+05	3,599E-02
22	22,5	1,63E+02	35,2	1,496E+04	1,261	1 289	1,372	1,897E+05	7,885E-02
23	22,1	1,80E+02	35,2	1,652E+04	1,261	1 269	1,351	2,168E+05	7,619E-02
24	21,8	8,30E+01	35,2	7,617E+03	1,261	1 248	1,328	2,514E+05	3,030E-02
25	21,4	2,00E+02	35,2	1,835E+04	1,261	1 225	1,303	2,960E+05	6,200E-02
26	20,9	2,12E+02	35,2	1,946E+04	1,261	1 200	1,277	3,542E+05	5,493E-02
27	20,5	1,04E+02	35,2	9,544E+03	1,261	1 173	1,249	4,310E+05	2,214E-02
28	20,0	2,38E+02	35,2	2,184E+04	1,261	1 144	1,218	5,359E+05	4,075E-02
29	19,4	2,53E+02	35,2	2,322E+04	1,261	1 113	1,185	6,820E+05	3,405E-02
30	18,8	2,00E+02	35,2	1,835E+04	1,261	1 080	1,149	8,893E+05	2,064E-02
31	18,2	2,06E+02	35,2	1,890E+04	1,261	1 044	1,111	1,191E+06	1,587E-02
32	17,6	2,97E+02	35,2	2,726E+04	1,261	1 007	1,071	1,644E+06	1,658E-02
33	16,9	3,16E+02	35,2	2,900E+04	1,261	966	1,028	2,352E+06	1,233E-02
34	16,1	3,34E+02	35,2	3,065E+04	1,261	923	0,982	7,313E+06	4,191E-03
35	15,3	3,52E+02	35,2	3,230E+04	1,261	877	0,934	9,249E+07	3,493E-04
36	14,5	2,74E+02	35,2	2,515E+04	1,274	837	0,891	9,470E+08	2,655E-05
37	13,6	2,86E+02	35,2	2,625E+04	1,292	797	0,848	1,129E+10	2,326E-06
38	12,6	4,04E+02	35,2	3,708E+04	1,314	754	0,802	1,796E+11	2,065E-07
39	11,6	4,29E+02	35,2	3,937E+04	1,341	708	0,754	4,006E+12	9,827E-09
40	10,6	4,49E+02	35,2	4,121E+04	1,375	660	0,703	1,322E+14	3,117E-10
41	9,5	4,68E+02	35,2	4,295E+04	1,419	610	0,649	6,965E+15	6,167E-12
42	8,3	3,03E+02	35,2	2,781E+04	1,477	557	0,593	6,408E+17	4,339E-14
43	7,1	1,76E+02	35,2	1,615E+04	1,560	501	0,534	1,230E+20	1,313E-16
44	5,8	1,20E+01	35,2	1,101E+03	1,685	443	0,471	6,019E+22	1,830E-20
45	4,4	0,00E+00	35,2	0,000E+00					0,000E+00
46	3,0	0,00E+00	35,2	0,000E+00					0,000E+00
47	1,6	0,00E+00	35,2	0,000E+00					0,000E+00
48	0,0	6,04E+06	0	0,000E+00					0,000E+00
	Total			6,001E+05				Miner sum	9,993E-01
Bending life				6,001E+05 cycles = 2,632E+05 hours = 3,002E+01 years					

The Woehler-damage curves are shown in Figure C.1.

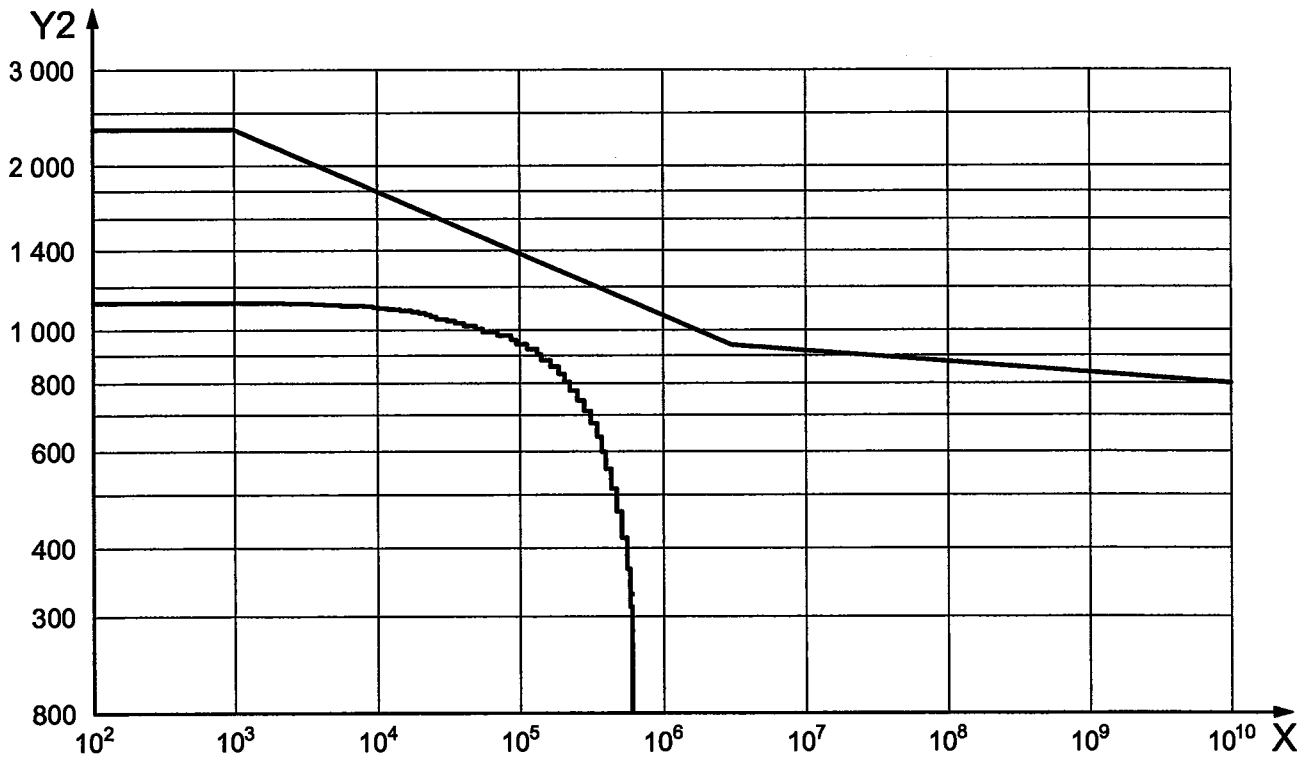
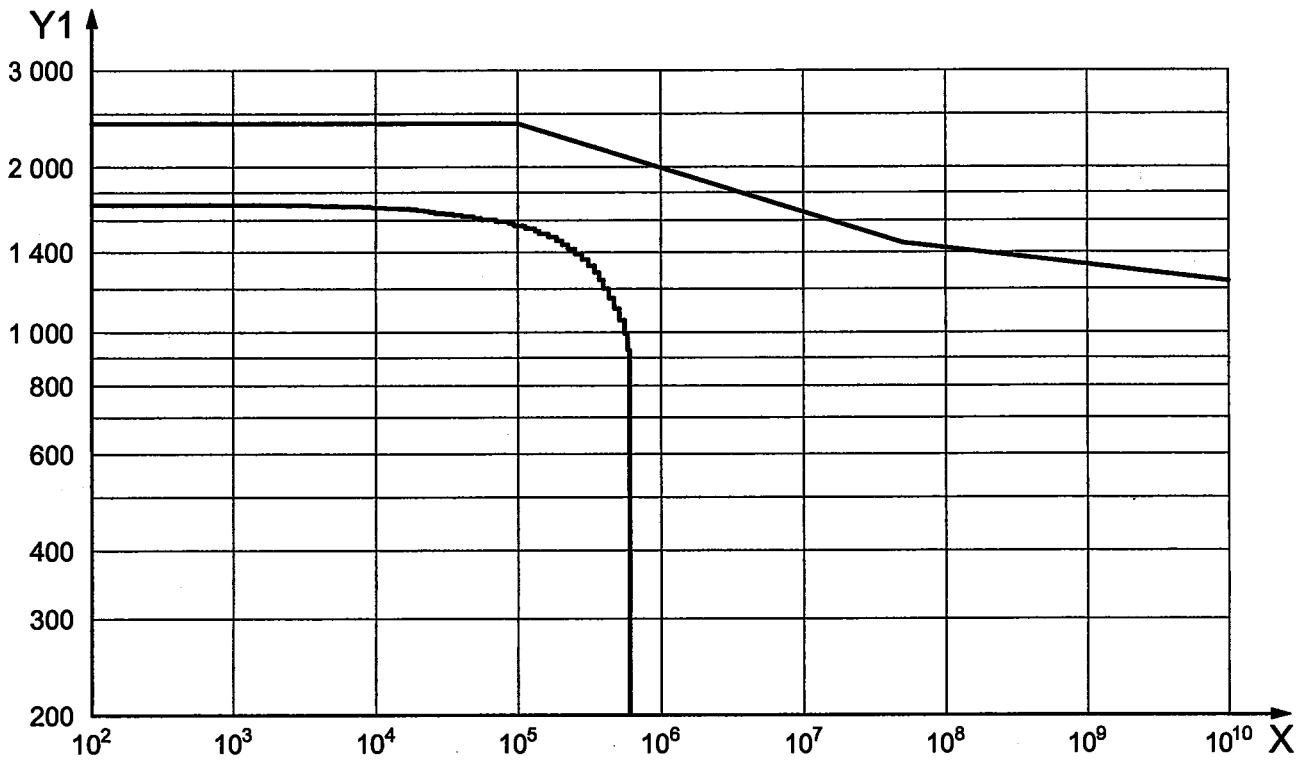

Key

- X number of load cycles, N_L
- Y1 contact stress, σ_H, σ_{HG} , N/mm²
- Y2 root stress, σ_F, σ_{FG} , N/mm²

Figure C.1 — Woehler damage curves

Bibliography

- [1] ISO 701:1998, *International gear notation — Symbols for geometrical data*
- [2] BUXBAUM, O. *Betriebsfestigkeit Verlag Stahleisen* (1986)
- [3] FRIEDRICH, G. Anwendung der Lebensdauerberechnung beim Entwurf und der Auswahl von Zahnradgetrieben, *Maschinenbautechnik*, Berlin 32 (1983) S. 457 ff
- [4] GNILKE, W. Lebensdauerberechnung mit Hilfe von Schadenslinien, *Antriebstechnik* 24 (1985) Nr. 9, S. 62 ff
- [5] GOLL, S. *Auslegung und Lebensdauer von Getriebeelementen*. VDI-Berichte Nr. 332 (1979) S. 37 ff
- [6] GRIESE, F.-W., HEINISCH, D. *Beitrag zur lebensdauerorientierten Getriebedimensionierung mit Hilfe von Lastkollektiven*. FVA-Forschungsheft Nr. 168 (1984)
- [7] KRAUSE, J.K. Predicting the Life of Mechanical Systems. *Machine Design*. November 22. 1979, pp. 96-102
- [8] MINER, M.A. Cumulative Damage in Fatigue, *Journal of Applied Mechanics*. Vol. 12. 1945. A159 - 164.
- [9] NELSON, D. Cumulative Fatigue Damage in Metals, Stanford University Ph. D., 1978, University Microfilms International. Ann Arbor. MI.
- [10] PALMGREN, A. Durability of Ball Bearings, ZDVDI. Vol. 68. No. 14, p. 339 (in German)
- [11] RENIUS, K.TH. Betriebsfestigkeitsberechnungen von Maschinenelementen in Ackerschleppern mit Hilfe von Lastkollektiven. *Konstruktion* 29 (1977) S. 85-93
- [12] SEIFRIED A., MUELLER P. *Wechselnde Betriebsbelastung, Ihre rechnerunterstützte Bestimmung, Auswertung und Berücksichtigung in der Konstruktion von Zahnradgetrieben*. VDI-Berichte Nr. 434 (1982) S. 29 ff
- [13] Verein zur Förderung der Forschung und Anwendung von Betriebsfestigkeitserkenntnissen in der Eisenhüttenindustrie (VBFeh). *Leitfaden für eine Betriebsfestigkeitsrechnung*, Verlag Stahleisen
- [14] WETZLER, R.M., Editor, Fatigue Under Complex Loading. Analyses and Experiments. *Advances in Engineering*, Vol. 6, Warrendale, Pennsylvania. SAE. 1977. pp. 137-145
- [15] ZENNER, H., GRIESE, F.-W, RAECKER, R. Steigerung der Zuverlässigkeit von Großgetrieben durch gezielte Auswertung vorhandener Betriebsuntersuchungen. Bericht Nr. ABF 31. VBFeh. Düsseldorf (1986)

ICS 21.200

Price based on 24 pages